



UR20

Technical Specification

The UR20, the first of our next-generation high performance cobots, has been redesigned from the ground up to provide up to 30% more speed and torque, advanced motion control capabilities, and first-class user experience.

UR cobots bring incredible versatility and unparalleled ease of use to your applications. The UR20 is no exception - its 20 kg payload and 1750 mm reach make it an ideal match for applications ranging from palletizing to machine loading.

Updated October 2023.

UR20

General specification

Payload	20 kg (44.1 lbs) in the entire workspace	
Reach	68.9 in	
Degrees of freedom	6 rotating joints	
Programming	12 inch touchscreen with PolyScope graphical user interface	
Power consumption (average)		
Maximum power	750 W	
Moderate operating settings	300 W	
Operating temperature range	Ambient temperature: 0-50°C (32-122°F)	
Safety functions	17 configurable safety functions	
In compliance with	EN ISO 13849-1 (PLd Category 3) and EN ISO 10218-1	

UR20 arm

Performance

Force sensing tool flange/torque sensor	Force, x-y-z	Torque, x-y-z
Range	200.0 N	20.0 Nm
Precision	5.5 N	0.2 Nm
Accuracy	10.0 N	0.1 Nm

Movement

Typical TCP speed	2 m/s	
Pose repeatability per ISO 9283	± 0.1 mm	
Axis movement	Working range	Maximum speed
Base	± 360°	± 120°/s
Shoulder	± 360°	± 120°/s
Elbow	± 360°	± 150°/s
Wrist 1	± 360°	± 210°/s
Wrist 2	± 360°	± 210°/s
Wrist 3	± 360°	± 210°/s

Features

IP classification	IP65 water protection	
Noise	< 65 dB(A)	
Arm mounting	Any orientation	
I/O Ports		
Digital In	2	
Digital Out	2	
Analog In	2	
Tool I/O power supply voltage	12/24 V	
Tool I/O power supply	2 A (Dual pin), 1 A (Single pin)	

Physical

Footprint	Ø 9.65 in 6 x M10 60° 4.13 in center	
Materials	Aluminum, plastic, steel	
Tool flange	EN ISO-9409-1-80-6-M8	
Connector type	M8 M8 8-pin female	
Cable length (robot arm)	236 in	
Weight including cable	141.1 lbs	
Humidity	≤ 90% RH (non-condensing)	

Contact

Universal Robots A/S
 Energivej 25
 5260 Odense
 Denmark
 +45 89 93 89 89
sales@universal-robots.com
universal-robots.com

3-Position Enabling Teach Pendant

Features

IP classification	IP54 water protection
Humidity	≤ 90% RH (non-condensing)
Display resolution	1280 x 800 pixels

Physical

Materials	Plastic
Teach pendant size (W x H x D)	11.8 in x 9.1 in x 1.97 in
Weight	3.961 lbs including 1 m of teach pendant cable
Cable length	177.17 in

Control Box

Features

IP Classification	IP44 water protection
Humidity	≤ 90% RH (non-condensing)
I/O Ports	
Digital In	16
Digital Out	16
Analog In	2
Analog Out	2
Quadrature digital inputs	4
I/O Power Supply	24V, 2A
Communication	
	500 Hz Control frequency
	Modbus TCP
	PROFINET, PROFIsafe (optional)
	Ethernet/IP
	USB 2.0, USB 3.0
	ROS/ROS2 driver support (optional, open source)
	Injection Molding Machine Interface (IMMI, optional)
Power Source	100-240 VAC, 47-440 Hz

Physical

Control Box Size (W x H x D)	18.2 in x 17.6 in x 10 in
Weight	26.5 lbs
Materials	Powder coated steel

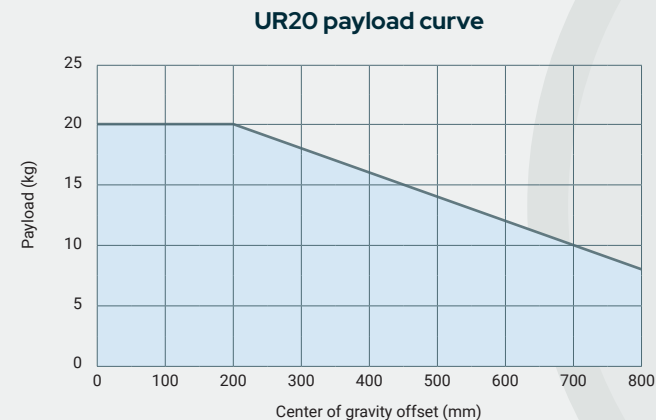

Recommended hole pattern for robot base

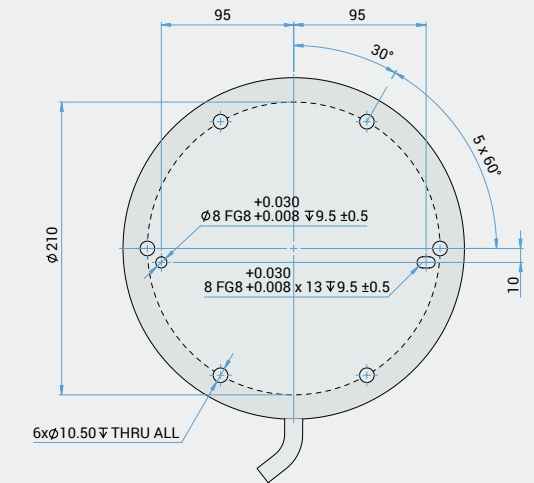

Mounting plate with pins for robot base

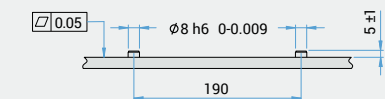

UR20 tool flange

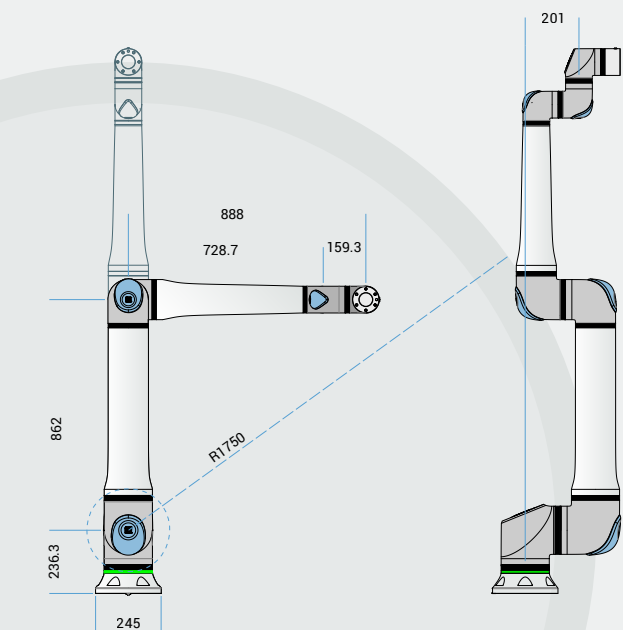
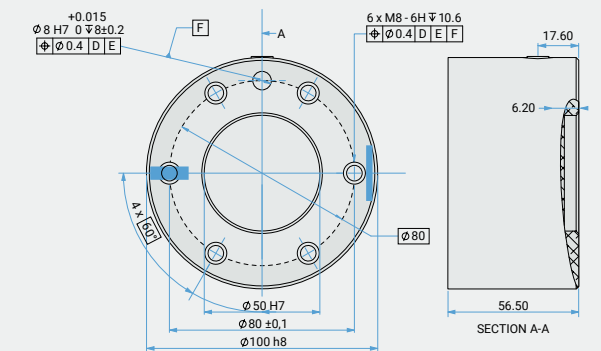

UNLESS OTHERWISE SPECIFIED:
 Dimensions are in millimeters. Tolerance ± 0.1 mm ± 0.5°